

SUR-CUT™ GUILLOTINE KNIFE ASSEMBLY

GC-250
GC-400
GC-630

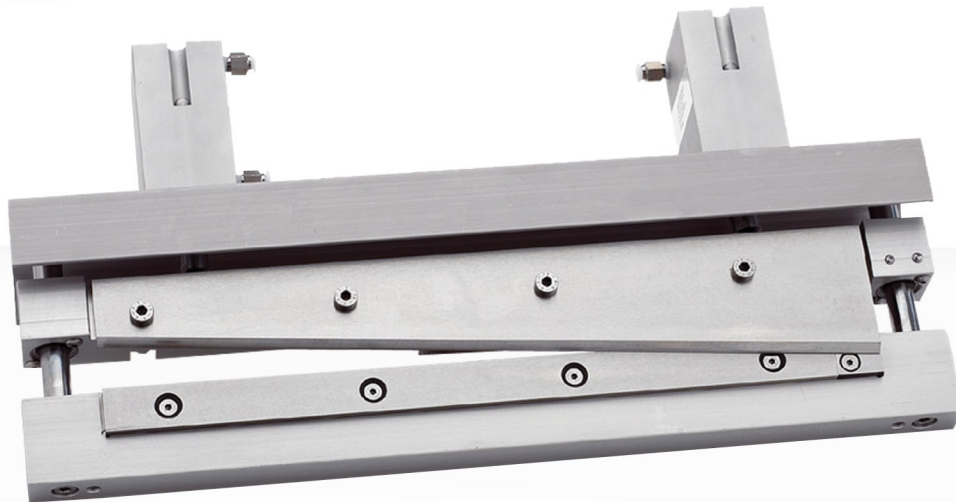

SUR-CUT™ GUILLOTINE KNIFE ASSEMBLY

GC SERIES TECHNICAL SPECIFICATION

Solid Models & Videos Available Online

AZCO Corp. offers complete, modular guillotine knife assemblies ready to install as stand-alone or in-line units. These midrange units can be mounted in any position for convenient operation and cut a wide variety of flexible materials. Mounting holes allow quick installation. We also offer our GO Series for narrower material and our GH Series for wider materials.

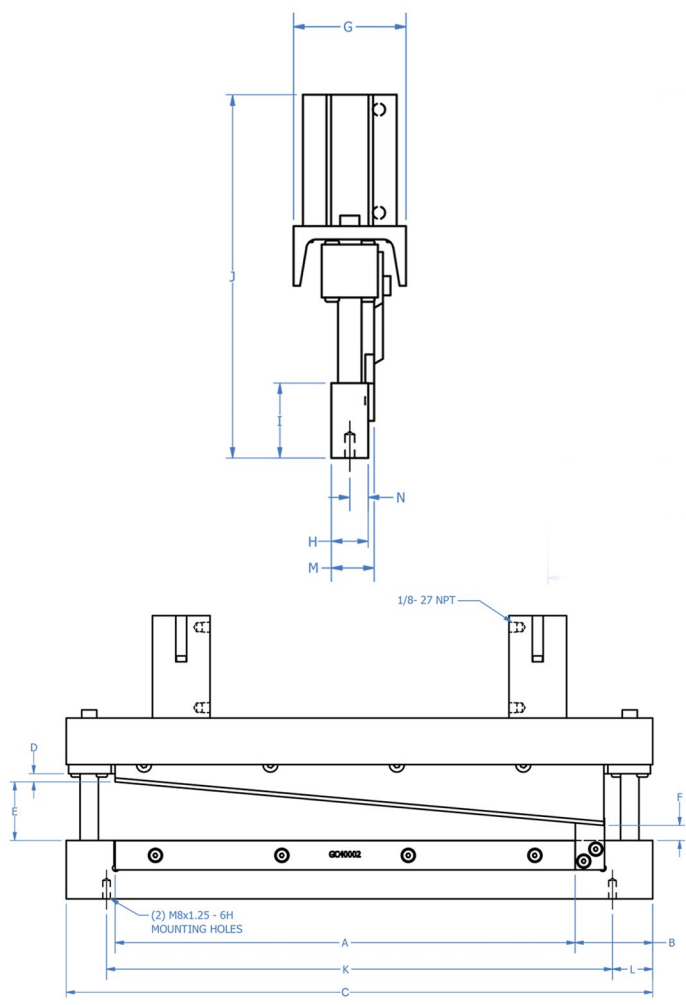

BENEFITS

- Proven off-the-shelf design
- Simple installation and hook-up
- Clean cuts
- Low maintenance
- Holes provided for mounting on flat, single-plane surfaces
- D2 hardened tool steel blades for long life

MATERIALS

- Films
- Foils
- Hook and loop
- Laminates
- Light gauge metals (.25mm/.01 in.)
- Non-wovens
- Paper
- Foam rubber
- Ribbon cables and many others

SPECIFICATIONS

- **Cutting Rate:** Up to 200 cuts per minute. Rate is governed by air pressure and flow rate.
- **Construction:** Aluminum anodized frame, tool steel blades, linear bearings.
- **Power Requirements:** 30-90 psi [2 - 6 bar] compressed air (depending on material).

OPTIONS

- SMARTKNIFE™ package
- Blade position sensors
- Custom blade geometry
- Variety of blade material and coatings
- Pneumatic or Spring hold-down clamp

MODEL	UNITS	SYMBOL:	A	B	C	D	E	F	G	H	I	J	K	L	M	N	WEIGHT	
GC-250	mm		250	67.5	360	12	34.2	10.1	76.2	25	51	245	290	35	29	12.5	kg	8
	in		9.8	2.7	14.2	0.5	1.3	0.4	3.0	1.0	2.0	9.6	11.4	1.4	1.1	0.5	lb	17
GC-400	mm		400	67.5	510	7	51	13	76.2	25	50.8	246	440	35	29	12.5	kg	12
	in		15.7	2.7	20.1	0.3	2.0	0.5	3.0	1.0	2.0	9.7	17.3	1.4	1.1	0.5	lb	27
GC-630	mm		630	67.5	740	8	49.3	11.3	76.2	25	50.8	302	670	35	29	12.5	kg	16
	in		24.8	2.7	29.1	0.3	1.9	0.4	3.0	1.0	2.0	11.9	26.4	1.4	1.1	0.5	lb	35



WARNING:
EQUIPMENT MUST BE GUARDED IN ACCORDANCE WITH ALL FEDERAL, STATE, AND LOCAL REQUIREMENTS



CUSTOM FEEDING & CUTTING SOLUTIONS

26 Just Road, Fairfield, NJ, 07004 | 973-439-1428 | azcocorp.com



visit us online!

